

Example of application

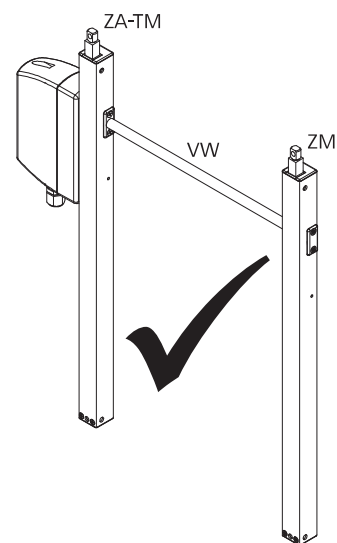
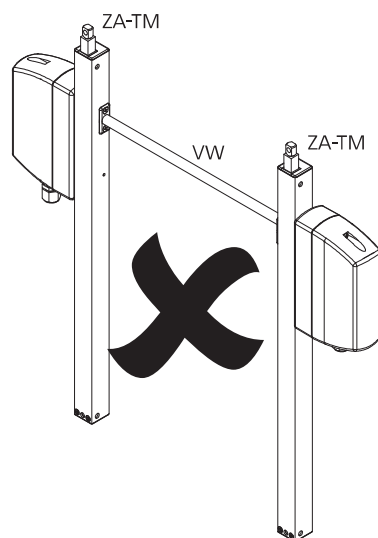

Usable drives

| Type | Art. No. | |
|-----------|-----------|-----|
| ZA-1-PLP | 27.005.00 | 114 |
| ZA-1-ACB | 27.011.00 | 118 |
| ZA-K | 27.007.02 | 122 |
| ZA-K-BSY+ | 27.007.01 | 126 |

Order drive with "Option TM"

Design

| Type | Art. No. | Stroke | Length | Diameter | Weight | Remark |
|---------|-----------|---------|---------|----------|---------|-----------------------------|
| ZM 500 | 20.005.00 | 500 mm | | | 1.10 kg | |
| ZM 800 | 20.005.10 | 800 mm | | | 1.60 kg | Only for topside mounting |
| ZM 1000 | 20.005.20 | 1000 mm | | | 1.90 kg | Only for topside mounting |
| ZM | 20.009.10 | | | | | Variable equipment possible |
| VW 1018 | 20.030.00 | | 1018 mm | 12 mm | 0.48 kg | |
| VW 1518 | 20.030.10 | | 1518 mm | 12 mm | 0.71 kg | |
| VW 2000 | 20.030.20 | | 2000 mm | 12 mm | 0.95 kg | |
| VW | 20.030.21 | | | | | Variable equipment possible |

ZA-TM



Performance features

- » Can be used for openings for smoke exhaust; D+H Euro SHEV in accordance with EN 12101-2; and for daily ventilation
- » For mechanically connecting to tandem drives using a VA connecting shaft
- » Tandem version for heavy loads, can be combined with: ZA drive (ZA-TM), ZA slave unit (ZM) and connecting shaft (VW)
- » High-speed function (HS) for especially fast opening windows in case of fire (SHEV)
- » Uniform load distribution on window sashes
- » Drive unit can be changed from left to right

Potential drive options



You can find the explanations for the icons on the last page.